

Cable Ties

Wing Mounted

Material: UL approved Nylon 66, 94V-2.

Application: The cable tie has an integral mounting device that locks into place when pushed into a pre-drilled hole.

Operating Temperature: -40°C to +85°C.

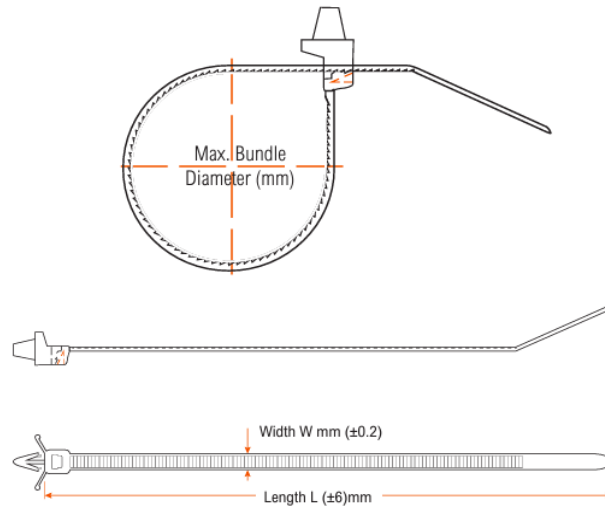

Tensile Strength Chart

Part No.	Colour	Width W (mm)	Length L (mm)	Mounting Hole Diameter (mm)	Max. Bundle Diameter (mm)	Min. Tensile Strength (kg)
PCT2-B	Black	2.5	112	4.6	25	8
PCT3-B	Black	4.8	132	6.0	25	22
PCT4-B	Black	4.8	201	6.0	50	22
PCT2-W	Natural	2.5	110	4.6	25	8
PCT3-W	Natural	4.8	132	6.0	25	22
PCT4-W	Natural	4.8	201	6.0	20	22

STORAGE AND USAGE OF NYLON CABLE TIES

Beal UK cable ties are made from high quality Nylon 66 resin. Moisture absorption is an essential factor for this material to retain its strength and maintain optimal performance. To this end, it is important for the cable ties to be kept in a sealed package wherever possible.

Below are some helpful storage suggestions:

1. The ideal storage temperature is around 23°C with the humidity over 50%.
2. Do not open the bag before use. Please try to finish the whole package of cable ties shortly after opening or reseal the bag until you are ready to use again.
3. Do not expose directly under sunlight (except UV weather resistant cable ties).
4. Avoid storing cable ties close to warm objects (such as heaters).